

# GP-2480 Series

## 38mm Graphic Panel with Touch Screen, Slim design, and better Reliability

### ■ GP(Graphic Panel) 2480

GP-2480 is a graphic interface device monitoring multiple control operations of PLC and other control units.

It indicates processing values or operation status of control devices and enables the communication between operators and user so that it replaces HMI(Human-Machine Interface) and MMI(Man-Machine Interface).

It displays control parameters and data on LCD screen, and they are easily set and managed by touching screen.

It offers better data transfer between GP and controller by the serial communication method.

The variables are displayed with tags; for example, the numerical value of temperature is shown with a tag, and the change in temperature for time can be graphed on the screen.

The data on GP-2480 can be edited and downloaded by user's preference using the software, GP Editor.

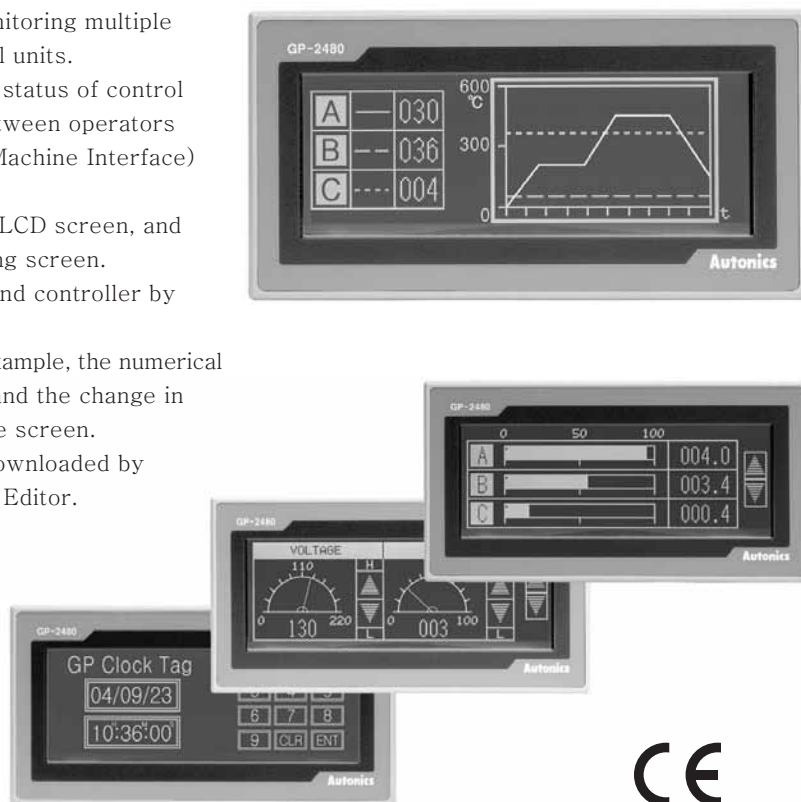

### ■ Features

- Slim 38mm of space saving device (W145×H74×D38mm)
- High resolution (240×80 dot), display max.400 characters
- 6×6, 8×8, ASC II, high quality view of numbers
- 8×16 ASC II, 16×16 of regional characters  
(1, 2, 3, 4, 5, 6, 7, 8 times bigger for width/0.5, 1, 2, 3, 4, 5 times bigger for height)
- Able to save max. 500 pages of user screen
- Communication between heterogeneous controllers
- Able to monitor 2 controllers simultaneously and relay the communication
- Multi monitoring function : Connect same controllers to PLC2 connection port (Max. 32 EA)
- Support language : Korean, English, Japanese, Chinese (Additional language support can be available by firmware)
- Support multi font (Various bitmap fonts, user-defined fonts)

Default font		8×16 pixel
Available characters	6×8 pixel	40 characters×10 lines=400 characters
	8×8 pixel	30 characters×10 lines=300 characters
	8×16 pixel	30 characters×5 lines=150 characters
	16×16 pixel	15 characters×5 lines=75 characters
	32×32 pixel	7 characters×2 lines=14 characters
Font size	Width	1~8 times
	Height	0.5, 1~5 times

- Device monitoring function : It is able to monitor the activities of connectable controller devices without designed data.
- Touch interface : It is able to operate GP using touch switch on front screen

# Graphic Panel

## ■ Specifications

Model	GP-2480-SBD0	GP-2480-SBD1		
Power supply	24VDC ±10%			
Power consumption	Max. 3.6W			
LCD type	STN Blue Negative			
Resolution	240×80 dots			
Display area	112.8mm×37.6mm			
Color	MONO(Blue, White)			
LCD visible angle	30° of Up/Down/Left/Right direction			
Backlight	White LED			
Battery life cycle	3 years at 25°C			
Brightness	Adjustable by software			
Serial communication	Each of RS232C, RS422	2 ports of RS232C		
Applicable device	PLC(Refer to "Communication manual"), Printer, Barcode reader			
Graphic drawing software	GP Editor			
Text font size	<ul style="list-style-type: none"> <li>• 400 characters for English</li> <li>• 6×8, 8×8 ASCII, and high quality view of numbers</li> <li>• 8×16 ASCII, 16×16 for other country letters(1, 2, 3, 4, 5, 6, 7, 8 times bigger for width / 0.5, 1, 2, 3, 4, 5 times bigger for height)</li> </ul>			
User Screen	Memory screen	500page(Memory 512KB)		
	Figure display	Line, Rectangle, Circle, Text, Bitmap		
	Tags	Numeral display	Display the designated device as numerical value. (Decimal, hexadecimal, octal, binary, real number)	
		ASCII display	Display the designated device value as ASCII character.	
		Time display	Display current time or date.	
		Alarm history	Register alarm history.	
		Alarm list	Display generated (not backed up) alarm.	
		Comment display	Display the designated comment as device status or value.	
		Lamp	Display lamp as device status.	
		Part display	Display the designated parts as device status and value.	
		Line graph	Display several device values with a graph of broken line.	
		Trend graph	Display change of device value for time with a graph of broken line.	
		Bar graph	Display a device value with a bar graph.	
		Statistic graph	Display a ratio of several device values with pie graph.	
		Panel meter	Display a device value as panel meter.	
		Touch key	Screen is switched, word/bit device values are set when it touched.	
	Numeral input	Configure user input value in device.		
	ASCII input	Configure user input ASCII code value in device.		
	System information function	Monitor/control GP operation from PLC.		
	Recipe function	Read/Write several PLC device collectively.		
	Security function	Only acceptable user can observe/operate important data.		
	Barcode read function	Connect barcode reader, read barcode.		
	Floating alarm function	Warning message is floated when alarm is generated.		
	Time operation	Specific bit device is ON/OFF for designated day and time.		
	Overlap window	Available to form dynamically overlapping another base screen on the base one.		
	Observe status function	Change PLC device status/value of PLC when trigger is generated.		
	System Screen	Monitoring	Monitor connected PLC device and change the status.	
Preference		Language selection	Designate system language and character set.	
		Channel connection	Configure connection device of serial port connected to CH1, CH2, editor, printer, barcode reader and serial setup.	
		Current time	Configure current date and time.	
		Delete user data	Delete user data.	
		Configuration/access key	Designate the configuration/access key position of system menu.	
		Buzzer	ON/OFF buzzer	
		Switching of user screen	Configure time for initial screen when power it on.	
		Backlight	Configure Backlight OFF time if there is no operation.	
		Battery	Display the percentage of battery remaining.	
		Contrast	Adjust LCD contrast.	
Configuration of function		Data transmission	Display during communication (Download/upload) between GP and editor.	
		Time switch	Configure time switch	
	Print out	Print alarm history with serial printer.		

(A) Counter

(B) Timer

(C) Temp. controller

(D) Power controller

(E) Panel meter

(F) Tacho/Speed/Pulse meter

(G) Display unit

(H) Sensor controller

(I) Switching power supply

(J) Proximity sensor

(K) Photo electric sensor

(L) Pressure sensor

(M) Rotary encoder

(N) Stepping motor &amp; Driver &amp; Controller

(O) Graphic panel

(P) Field network device

(Q) Production stoppage models &amp; replacement

# GP-2480 Series

## Specifications

System Screen Data check	Basic screen	Display title and number of base screen user made.
	Window screen	Display title and number of window screen user made.
	Comment	Display comment list downloaded in main body.
	Check using memory	Display status of using graphic drawing memory.
	Check model and version	Display model and firmware version of GP.
Ambient temperature		0°C ~ 50°C (at non-freezing status)
Storage temperature		-20°C ~ 60°C (at non-freezing status)
Ambient humidity		35% ~ 85% RH (at non-dew status)
Insulation resistance		Min. 100MΩ (at 500VDC mega)
Ground		3rd grounding (Max. 100Ω)
Dielectric strength		500VAC (50/60Hz) for a minute
Noise strength		The square wave noise (Pulse width 1μs) by the noise simulator with ±1000V R/S phase and repetition frequency 60Hz
Vibration	Mechanical	0.75mm amplitude at frequency of 10~55Hz (for a minute) in each of X, Y, Z directions for an hour
	Malfunction	0.5mm amplitude at frequency of 10~55Hz (for a minute) in each of X, Y, Z directions for 10 minutes
Protection structure		IP65F for front panel (IEC standard)
Accessory		Fixing bracket : 4 pcs, Rubber waterproof ring, Battery (Built-in)
Unit weight		Approx. 300g

## Dimensions

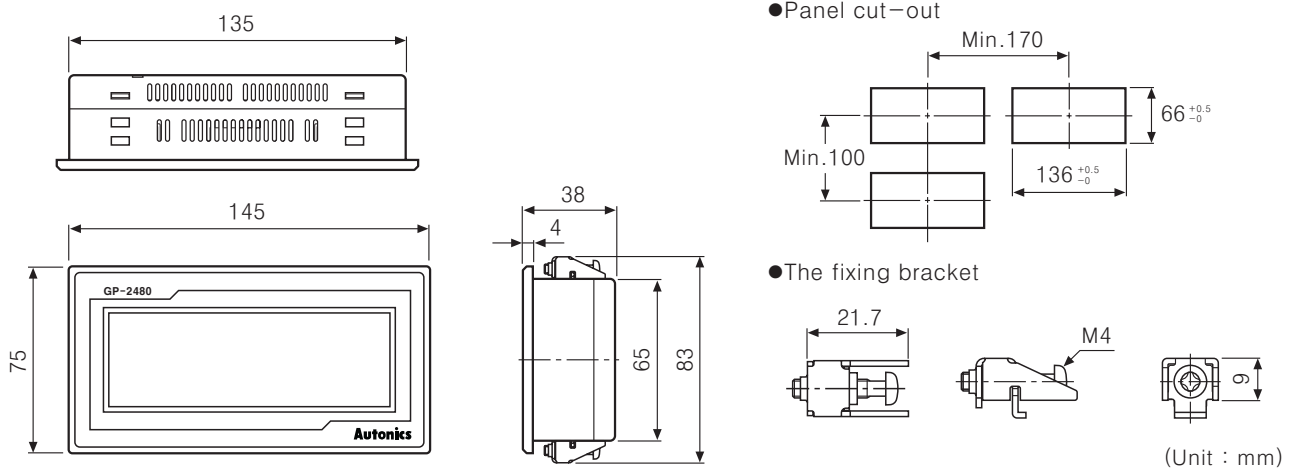

## Part description

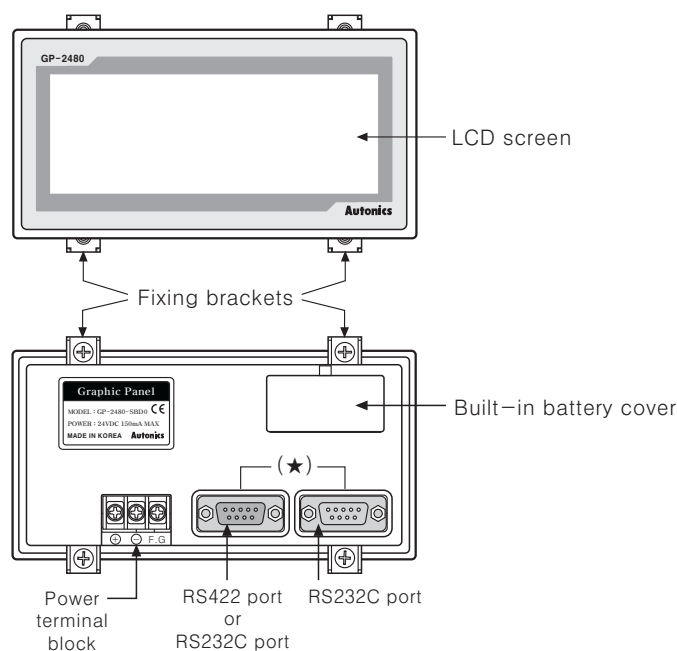

## Installation

1. Set a rubber waterproof ring in GP.
2. Set GP in panel.
3. Set brackets in 4 bracket slots and fix them.

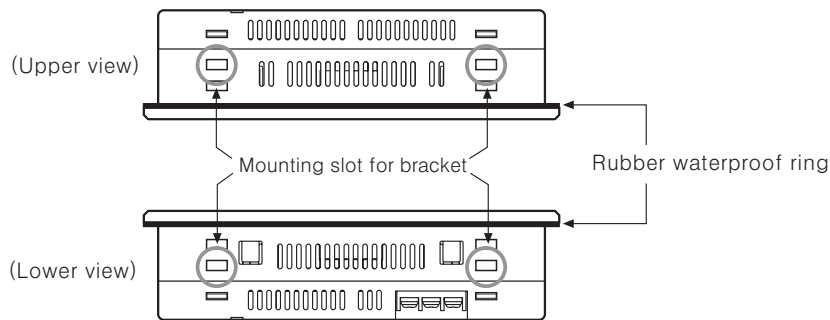

### ● Mounting bracket

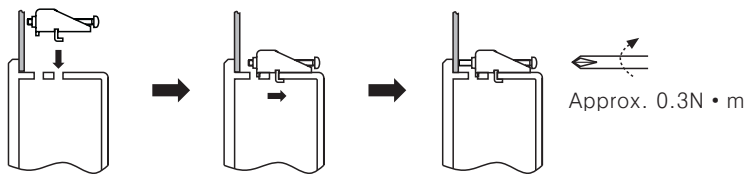

## Connection wiring

- Please use at least 0.75mm<sup>2</sup> power wire, at least 1.25mm<sup>2</sup> ground wire.
- Please use crimp-on type ring terminal with min.3mm of inside diameter and max. 6mm of external diameter.
- Please make sure the power is OFF before connect the power wire.
- Please check power polarity.
- Please tighten screws of each terminal with 0.5~0.8 N · m torque.
- Ground resistance should be max.100Ω, it is required to ground separately.

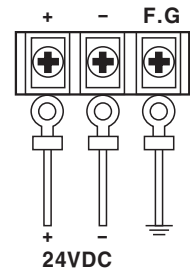

## Serial interface

- Connectable devices including PC, PLC, Serial printer, barcode reader and various controllers can be connected to RS232C, RS422.
- Set the device connected into the port in system configuration. Refer to "GP user manual" for the details and "Communication manual" for connection of PLC.

Port	PIN		Port	PIN	
<b>RS232C-A, RS232C-B</b>  D-Sub 9Pin Male	1	Non-used	<b>RS422-A</b>  D-Sub 9Pin Female	1	TXD+
	2	RXD		2	RXD+
	3	TXD		3	RTS-
	4	DTR		4	CTS+
	5	SG		5	SG
	6	DSR		6	TXD-
	7	Non-used		7	RXD-
	8	Non-used		8	RTS+
	9	Non-used		9	CTS-

## Software(GP Editor)

Please visit our website([www.autonics.com](http://www.autonics.com)) and download software and manual.

< Computer specification for using software >

Item	Minimum specification	Recommended specification
System	Pentium II	Min. Pentium III
Memory	64MB	Min. 128MB
Hard disk	Over 50MB of available space	Over 100MB of available space
Resolution	800×600	Min. 800×600
Operating system	Windows 98/NT/2000/Me/XP	

## Manual

### ● GP user manual

Refer to "GP user manual" for more information about design screen data using GP Editor and instructions of GP.

### ● Communication manual

Refer to "Communication manual" for more information about serial connection of external device, such as PLC.

## Battery replacement

Please contact out distributor to replace battery. It may cause an explosion or a fire when improper battery is used.

(A)  
Counter

(B)  
Timer

(C)  
Temp.  
controller

(D)  
Power  
controller

(E)  
Panel  
meter

(F)  
Tacho/  
Speed/  
Pulse  
meter

(G)  
Display  
unit

(H)  
Sensor  
controller

(I)  
Switching  
power  
supply

(J)  
Proximity  
sensor

(K)  
Photo  
electric  
sensor

(L)  
Pressure  
sensor

(M)  
Rotary  
encoder

(N)  
Stepping  
motor &  
Driver &  
Controller

(O)  
Graphic  
panel

(P)  
Field  
network  
device

(Q)  
Production  
stoppage  
models &  
replacement

# GP-2480 Series

## ■ Connectable device with GP

Series	Connectable device	Connection type	GP-2480 (Max. V2.7)	GP-2480 (Min. V3.0)
LS Master-K	MK-10S1	CPU direct connection loader	○	○
	MK-80S	CPU direct connection loader	○	○
	MK-120S	CPU direct connection loader	○	○
	MK-200S	CPU direct connection loader	○	○
	MK-300S	CPU direct connection loader	×	○
	MK-1000S	CPU direct connection loader	×	○
LS Glofa	GM4	CPU direct connection loader	○	○
	GM6	CPU direct connection loader	○	○
	GM7U	CPU direct connection loader	×	○
LS CNET (CPU 내장 Cnet)	MK-80S	Cnet	○	○
	MK-120S	Cnet	○	○
	MK-200S	Cnet	○	○
LS CNET (Cnet unit 사용시)	MK-80S	Cnet	○	○
	MK-120S	Cnet	○	○
	MK-200S	Cnet	○	○
	MK-300S	Cnet	×	○
	MK-1000S	Cnet	×	○
LS XGB	XBM_DR16	Cnet	×	○
LS XGT	XGT	Cnet	×	○
OEMAX(구 SAMSUNG)	N70	CPU direct connection loader	○	○
	N70Plus	CPU direct connection loader	○	○
OEMAX FARA	NX7	CPU direct connection loader	×	○
	NX70	CPU direct connection loader	×	○
MITSUBISHI FX	FX1S	CPU direct connection loader	○	○
	FX1N	CPU direct connection loader	○	○
	FX2N	CPU direct connection loader	○	○
	FX2NC	CPU direct connection loader	○	○
	FX3U	CPU direct connection loader	×	○
NAIS FP	FP0-C10	CPU direct connection loader	○	○
	FP0-C14	CPU direct connection loader	○	○
	FP0-C16	CPU direct connection loader	○	○
	FP0-C32	CPU direct connection loader	○	○
	FPG-C24R2	CPU direct connection loader	○	○
	FPG-C32T	CPU direct connection loader	○	○
OMRON SYSMAC C	CPM1A	CPU direct connection loader	○	○
OMRON Temperature controller	E5AN	Modbus	○	○
	E5AR	Modbus	○	○
	E5CN	Modbus	○	○
	E5EN	Modbus	○	○
	E5ER	Modbus	○	○
AUTONICS	MT Series	Private communication	○	○
	MT Series (Modbus type)	Modbus	×	○
	MP Series	Private communication	○	○
	THD Series	Modbus	○	○
	TZ/TZN Series	Private communication	○	○
	LP-S044	CPU direct connection loader	×	○
KONICS	DPU Series	Modbus	×	○
DELTA	DTB Series	Modbus	○	○
UNIVERSAL	UNIVERSAL	Modbus(Slave)	○	○

※ GP/LP connectable device list will keep updated according to the upgrade of GP Editor or additional patch. It is recommended to use the latest version of Editor.

※ Applicable GP/LP firmware version is determined by GP Editor version. Whole GP system goes down if non-compatible firmware version is used.

※ Visit our website ([www.autonics.com](http://www.autonics.com)) to check update of latest GP Editor and GP/LP firmware and to get more detailed instructions.

※ Refer to the user manual to select proper communication cable between GP and controllers. (Sold separately)

## Application

### ◎Complicated environment of operation and control

It graphicalzes mechanical control components such as button, switch and lamps so that saves cost and space and improves the preservation of devices.



### ◎Setting and change of production process

It memorizes the set conditions (Recipe) of process in GP, and it sets or changes commands to PLC without PC. It enhances reliability of production line with fast corresponding alarm of error and preserving the history.

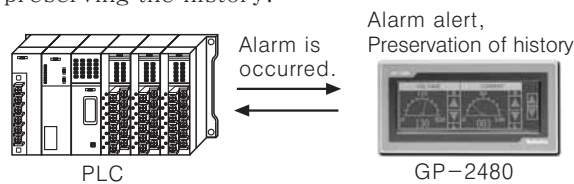

### ◎Controllers with complicated setting

It sets complicated or non-displaying controller (Thermometer/hygrometer, temperature controller etc).

#### 1)Temperature/Humidity without display device



#### 2)Temperature controller

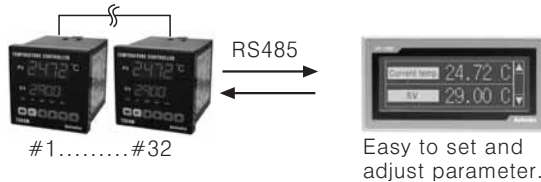

### ◎Data control

It prints alarm history of controller using printer. It reads the data from barcode reader and save it in PLC.

#### 1)PLC/Printer

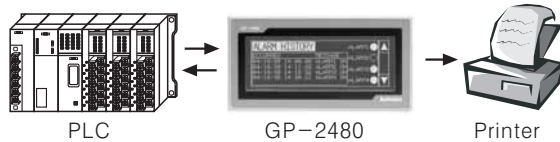

#### 2)Barcode reader/PLC



### ◎Communication between heterogeneous controllers

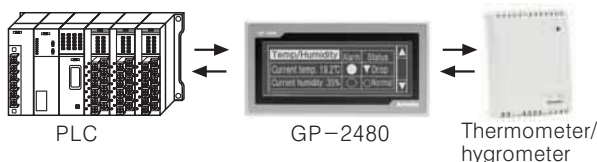

## Precaution for using

1. Do not press touch panel with hard and sharp object.
2. Please store the device in the recommended temperature range, or LCD panel can be damaged.
3. Please check pin number shown in "Communication manual" when connect communication port.
4. Do not block the ventilating opening of this product.
5. Do not use or store it in a place with direct ray of light or dust.
6. Do not use or store it in a place with shock or vibration.
7. The ground wire of GP should be grounded separately. The ground resistance should be max.100Ω, please use the wire of min. 1.25mm<sup>2</sup> dimension.
8. Please check the pin number and connect to GP communication port.
9. Please tighten bolt on terminal block with specified tightening torque.
10. When liquid crystal from the broken LCD is smeared on your skin, wash it for 15 minutes. If it is gotten in your eye, wash it for 15 minutes and contact a medical specialist for more information.
11. Do not inflow dust or wire dregs into the unit.
12. For cleaning, do not use water or an oil-based detergent, use dry towels.
13. It should be done away regarded as an industrial waste.

(A)  
Counter

(B)  
Timer

(C)  
Temp.  
controller

(D)  
Power  
controller

(E)  
Panel  
meter

(F)  
Tacho/  
Speed/  
Pulse  
meter

(G)  
Display  
unit

(H)  
Sensor  
controller

(I)  
Switching  
power  
supply

(J)  
Proximity  
sensor

(K)  
Photo  
electric  
sensor

(L)  
Pressure  
sensor

(M)  
Rotary  
encoder

(N)  
Stepping  
motor &  
Driver &  
Controller

(O)  
Graphic  
panel

(P)  
Field  
network  
device

(Q)  
Production  
stoppage  
models &  
replacement